

BENUTZERHANDBUCH
OWNER'S MANUAL



X-ONE

CLASS D MONO AMPLIFIER

TABLE OF CONTENT

SAFETY INSTRUCTIONS	14
INSTALLATION INSTRUCTIONS	15
X-ONE	17
Features and operational controls	17
Interconnection example Low Pass-Mode (standard subwoofer operation)	18
Interconnection example Master/Slave-Mode	19
SPECIFICATIONS	21
TROUBLE SHOOTING	22



This symbol adverts you an important reference note on the following pages. Attend these reference notes by any means, otherwise damage of the device or the vehicle may be caused. Furthermore serious injuries may be caused by not following these reference notes.



REFERENCE NOTE!

VERY IMPORTANT ADVICE FOR THE INSTALLATION AND OPERATION IN NEWER VEHICLES!

In vehicles with a newer year of manufacturing (since approx. 2002), normally computer controlled diagnosis- and controlling systems are applied - like CAN-BUS or MOST-BUS interfaces. By the installation of a car audio amplifier a new appliance will be added to the 12V on-board electrical system, which may cause under several circumstances error messages or may interrupt this factory made diagnosis system, as a result of high stress peaks and a higher power consumption. Thus to this, depending on model and manufacturer, the driving safety or important security systems like airbags, ESC or others could be interrupted.

If you plan to operate the amplifier in a vehicle like described above, please follow these instructions:

- **Admit the installation only by a skilled specialist, best by a service company, which is specialized on maintenance and repairing your vehicle and which is familiar with the electrical on-board system of the vehicle.**
- **After the installation, order by any means a computer based diagnosis of the on-board system by your service company to detect possible malfunctions or error messages.**
- **If the on-board system is interrupted by the installation of the amplifier, in-between installed power capacitors can stabilize the electrical on-board system and ensure a proper and stable operation.**
- **The best solution is the integration of an additional second 12 V electrical system for the complete sound system, which can be operated independently via a own battery supply.**

CONSULT BY ANY MEANS YOUR CAR SPECIALIZED SERVICE COMPANY!

PLEASE KEEP THIS MANUAL FOR LATER PURPOSES!

SAFETY INSTRUCTIONS

PLEASE OBSERVE THE FOLLOWING ADVICES BEFORE THE FIRST OPERATION!

THE PURCHASED DEVICE IS ONLY SUITABLE FOR AN OPERATION WITH A 12V ON-BOARD ELECTRICAL SYSTEM OF A VEHICLE. Otherwise fire hazard, risk of injury and electric shock consists.

PLEASE DO NOT MAKE ANY OPERATION OF THE SOUND-SYSTEM, WHICH DISTRACT YOU FROM A SAFE DRIVING. Do not make any procedures, which demand a longer attention. Perform these operations not until you have stopped the vehicle on a safe place. Otherwise the risk of accident consists.

ADJUST THE SOUND VOLUME TO AN APPROPRIATE LEVEL, THAT YOU ARE STILL ABLE TO HEAR EXTERIOR NOISES WHILE DRIVING. High performance sound systems in vehicles may generate the acoustic pressure of a live concert. The permanent listening to extrem loud music may cause the loss of your hearing abilities. The hearing of extreme loud music while driving may derogate your cognition of warning signals in the traffic. In the interests of the common safeness, we suggest to drive with a lower sound volume. Otherwise the risk of accident consists.

DO NOT COVER COOLING VENTS AND HEATSINKS. Otherwise this may cause heat accumulation in the device and fire hazard consists.

DO NOT OPEN THE DEVICE. Otherwise fire hazard, risk of injury and electric shock consists. Also this may cause a loss of the warranty.

REPLACE FUSES ONLY WITH FUSE WITH THE SAME RATING. Otherwise fire hazard and risk of electric shock consists.

DO NOT USE THE DEVICE ANY LONGER, IF A MALFUNCTION, WHICH REMAINS UNREMEDIED. Observe in this case the section TROUBLE SHOOTING. Otherwise risk of injury and the damage of the device consists. Commit the device to an authorized retailer.

THE INSTALLATION OF A POWER CAPACITOR WITH SUFFICIENT CAPACITY IS RECOMMENDED. High performance amplifiers cause high potential voltage drops and need a high power consumption at a high volume level. To relieve the vehicle's on-board system, it is recommended to install a power capacitor between the battery and the device which works as buffer. Consult your car audio retailer for the appropriate capacity.

INTERCONNECTION AND INSTALLATION SHOULD BE ACCOMPLISHED BY SKILLED STAFF ONLY. The interconnection and installation of this device demands technical aptitude and experience. For your own safeness, commit the interconnexion and installation to your car audio retailer, where you have purchased the device.

DISCONNECT THE GROUND CONNECTION FROM THE VEHICLE'S BATTERY BEFORE INSTALLATION. Before you start with the installation of the sound system, disconnect by any means the ground supply wire from the battery, to avoid any risk of electric shock and short circuits.

CHOOSE A APPROPRIATE LOCATION FOR THE INSTALLATION OF THE DEVICE. Look for a appropriate location for the device, which ensures a sufficient air circulation. The best places are spare wheel cavities, and open spaces in the trunk area. Less suitable are storage spaces behind the side coverings or under the car seats.

DO NOT INSTALL THE DEVICE AT LOCATIONS, WHERE IT WILL BE EXPOSED TO HIGH HUMIDITY AND DUST. Install the device at a location, where it will be protected from high humidity and dust. If humidity and dust attain inside the device, malfunctions may be caused.

MOUNT THE DEVICE AND OTHER COMPONENTS OF THE SOUND SYSTEM SUFFICIENTLY. Otherwise the device and components may get loose and act as dangerous objects, which could cause serious harm and damages in the passenger room.

ENSURE NOT TO DAMAGE COMPONENTS, WIRES AND CABLES OF THE VEHICLE WHEN YOU DRILL THE MOUNTING HOLES. If you drill the mounting holes for the installation into the vehicle's chasis, ensure by any means, not to damage, block or tangent the fuel pipe, the gas tank, other wires or electrical cables.

ENSURE CORRECT CONNECTION OF ALL TERMINALS. Faulty connections may could cause fire hazard and lead to damages of the device.

DO NOT INSTALL AUDIO CABLES AND POWER SUPPLY WIRES TOGETHER. Observe while installation not to lead the audio cables between the headunit and the amplifier together with the power supply wires on the same side of the vehicle. The best is a areal separated installation in the left and right cable channel of the vehicle. Therewith a overlap of interferences on the audio signal will be avoided. This stands also for the equipped bass-remote wire, which should be installed not together with the power supply wires, but rather with the audio signal cables.

ENSURE THAT CABLES MAY NOT CAUGHT UP IN CLOSE-BY OBJECTS. Install all the wires and cables like described on the following pages, therewith these may not hinder the driver. Cables and wires which are installed close-by the steering wheel, gear lever or the brake pedal, may caught up and cause highly dangerous situations.

DO NOT SPLICE ELECTRICAL WIRES. The electrical wires should not be bared, to provide power supply to other devices. Otherwise the load capacity of the wire may get overloaded. Use therefor a appropriate distribution block. Otherwise fire hazard and risk of electric shock consists.

DO NOT USE BOLTS AND SCREW NUTS OF THE BRAKE SYSTEM AS GROUND POINT. Never use for the installation or the ground point bolts and screw-nuts of the brake system, steering system or other security-relevant components. Otherwise fire hazard consists or the driving safety will be derogated.

ENSURE NOT TO BEND OR SQUEEZE CABLES AND WIRES BY SHARP OBJECTS. Do not install cables and wires not close-by movable objects like the seat rail or may be bended or harmed by sharp and barbed edges. If you lead a wire or cable through the hole in a metal sheet, protect the insulation with a rubber grommet.

KEEP AWAY SMALL PARTS AND JACKS FROM CHILDREN. If objects like these will be swallowed, a risk of serious injuries consists. Consult promptly a medical doctor, if a child swallowed a small object.

INSTALLATION INSTRUCTIONS



REFERENCE NOTE

Before you start with the installation of the sound system, disconnect by any means the GROUND connection wire from the battery, to avoid any risk of electric shock and short circuits.

MECHANICAL INSTALLATION

Avoid any damage removing of the components of the vehicle like wires, cables, board computer, seat belts, gastank or the like.

Ensure that chosen location provide sufficient air circulation for the amplifier. Do not mount the device into small or sealed spaces without air circulation near by heat dispersing parts or electrical parts of the vehicle.

Do not mount the amplifier on top of a subwooferbox or any other vibrating parts, thereby parts in the inside of the amplifier may get loosen.

The wires and cables of power supply and the audio signal must be as short as possible, to avoid any losses and interferences.

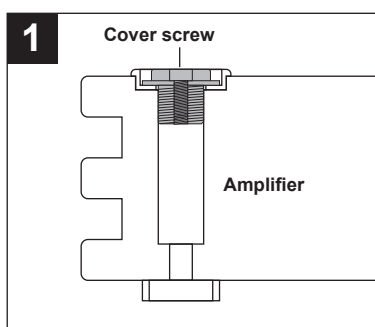

On each corner of the amplifier you find mounting openings for fixing the amplifier into your vehicle. These openings are covered by cover screws, which have to be removed before.

Please ensure during the installation, that you don't scratch or damage the amplifier surface with the tools.

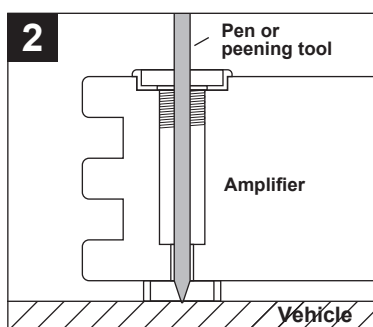

After removing the cover screws, uphold the amplifier to the chosen mounting location in the vehicle. Then mark the four drill holes with an appropriate pen or peening tool through the mounting openings.

Observe that enough space remains for the installation of the cables and ensure that they will not be bended and have sufficient pull relief.

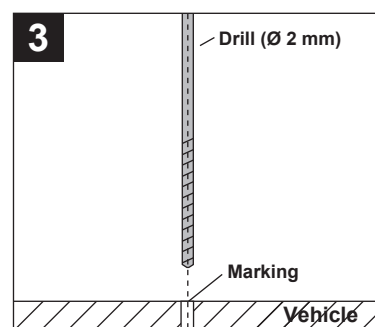

Put the amplifier aside and then drill the four holes for the mounting screws at the before marked locations.

Please ensure not to damage any components of the vehicle while drilling the holes. Alternatively (depends on the material of the surface) you can also use self-tapping screws.

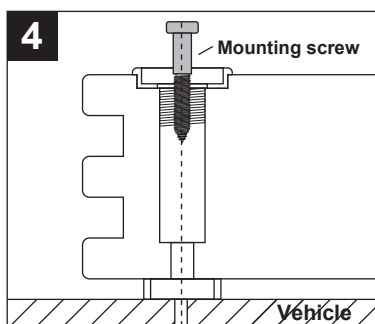

Then uphold the amplifier to the chosen position and fix the screws through the holes of the mounting brackets into the drilled screwholes.

Ensure that the mounted amplifier is fixed tight and not get loosen.

Then screw back the cover screws into the mounting opening.

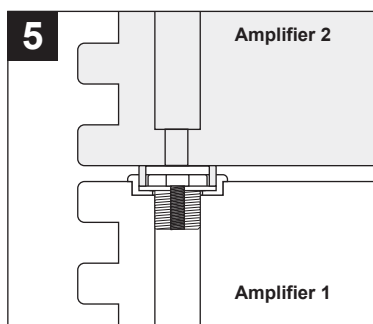

If you own a second ESX XENIUM amplifier, you are able to mount the two amplifiers over each other.

After installing "Amplifier 1", follow the "Section 1" for "Amplifier 2" like described above.

Then put "Amplifier 2" carefully onto the designated sockets of "Amplifier 1". Please ensure during the installation, not to damage the amplifier surface.

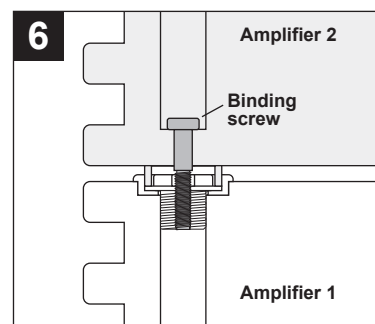

Screw both amplifiers together by using the four provided binding screws inside the mounting openings.

Ensure that the mounted amplifier is fixed tight and not get loosen.

Then screw back the cover screws into the mounting opening.

INSTALLATION INSTRUCTIONS

ELECTRICAL INTERCONNECTION

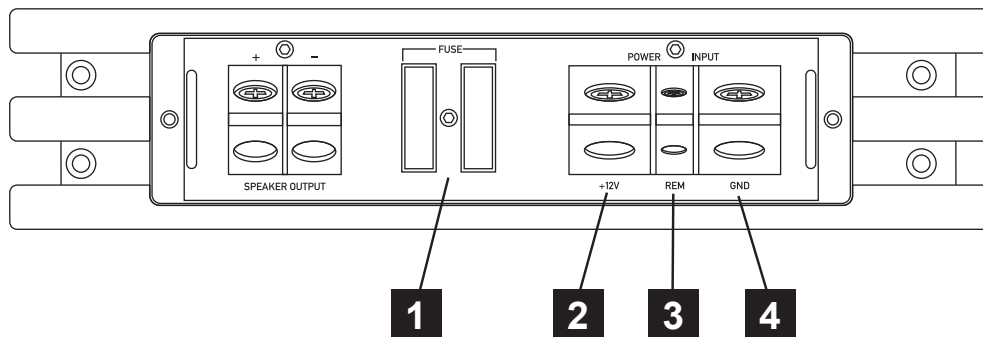

BEFORE THE CONNECTION

For the professional installation of a sound system appropriate wiring kits are available in car audio retailer stores. Attend the sufficient profile section (at least 20 mm²), the suitable fuse rating and the conductivity of the cables when you purchase your wiring kit. Clean and remove rust-streaked and oxidized areas on the contact points of the battery and the ground connection. Make sure that all screws are fixed tight after the installation, because loosely connections may cause malfunctions, insufficient power supply or interferences. We recommend therefore the **ESX SX25WK** wirekit.

1 FUSE

The inserted fuses protect the amplifier from shorts and capacity overload. Replace defective fuses only with fuses of the same type and rating (2 x 40 A).

2 BATT+12V

Connect the BATT+12V-terminal with the +12V pole of the vehicle's battery. Use therefor a suitable cable with a sufficient cross section (min. 20 mm²) and install a additional in-line fuse. For safety reasons the distance between the fuseblock and the battery must be shorter than 30 cm. Do not install the fuse into the fuseblock until the installation is accomplished.

3 REM (TURN-ON SIGNAL)

Connect the turn-on signal (e.g. automatic antenna) or the turn-on remote signal of your headunit with the REM-terminal of the amplifier. Use therefor a suitable cable with a sufficient cross section (0,5 mm²). Thereby the amplifier will turn on or off automatically with your headunit.

4 GND

Connect the GROUND terminal with a suitable contact ground point on the vehicle's chassis. The ground wire must be as short as possible and must be connected to a blank metallic point at the vehicle's chassis. Ensure that this ground point has a stable and safe electrical connection to the negative "-"pole of the battery. Check this ground wire from the battery to the ground point if possible and enforce it, if required. Use a ground wire with a sufficient cross section (at least 20 mm²) and the same size like the plus (+12V) power supply wire.



REFERENCE NOTE

Installation of RCA/Audio signal cables and power supply.

Attend while installation not to lead the audio cables between the headunit and the amplifier together with the power supply wires on the same side of the vehicle. The best is a areal separated installation in the left and right cable channel of the vehicle. Therewith a overlap of interferences on the audio signal will be avoided. This stands also for the equipped bass-remote wire, which should be installed not together with the power supply wires, but rather with the audio signal cables.

FUNCTIONS AND OPERATIONAL CONTROLS

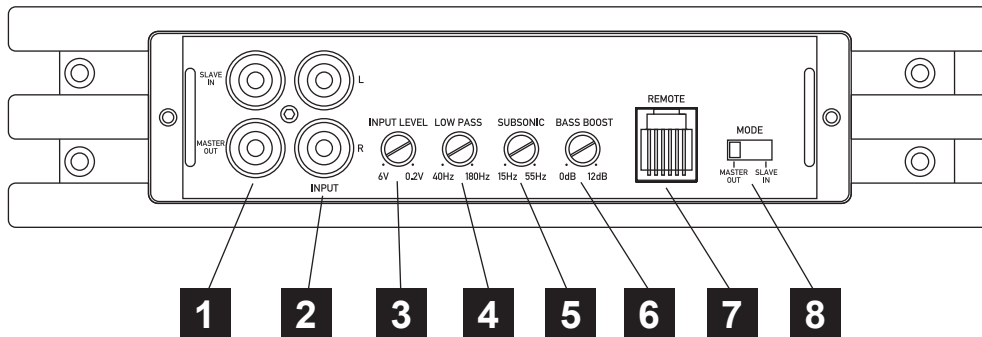

- 1** The **MASTER OUT / SLAVE IN RCA jacks** are suitable to connect an additional amplifier in MASTER/SLAVE mode. Attend therefore the chapter **Interconnection Example: MASTER/SLAVE** on page 19.
- 2** The **LINE INPUT RCA jacks** must be connected with the RCA output jacks of the headunit. Both jacks must be used. If your headunit provide only one RCA jack, you need to split the signal with a y-connector.
- 3** The **INPUT LEVEL controller** adjusts the input sensitivity of the amplifier to align the audio signal from the head unit. The input sensitivity is adjustable from 6 to 0.2 Volts.
- 4** The **LOW PASS controller** adjusts the cut-off point of the frequency range to above. The cut-off frequency is continuously adjustable from 40 Hz to 180 Hz.
- 5** The **SUB SONIC controller** (Subsonicfilter) limits the ultralow and not hearable frequencies of the audiosignal to below, to avoid a mechanical and electrical overloading on the subwoofer. The cut-off frequency is adjustable from 15 to 55 Hz and depends on the size of the subwoofer.
- 6** The **BASS BOOST** controller adjusts the bass enhancement between 0db and +12dB.
- 7** Connect the **REMOTE port** with the bass remote controller (only in the MASTER mode). The bass remote controller adjust the bass level e.g. out of the driver's seat. Please use only the enclosed bass remote controller and cable.
- 8** The **SLAVE IN/MASTER OUT switch** selects the required operation mode of the amplifier.
In the **SLAVE-Mode** the amplifier works as a SLAVE amp, this means only the audiosignal of the MASTER amp will be amplified. All controllers on the SLAVE Amp are without function and will be assumed by the MASTER amp.
In the **MASTER-Mode** (Low Pass mode) you are able to limit the frequencies to above with the LOW PASS controller. All controllers are active. **NOTE: By using only one amplifier, the Mode-Switch must set to the position MASTER OUT.**

INTERCONNECTION EXAMPLE Low Pass-Mode (Standard Subwoofer Operation)

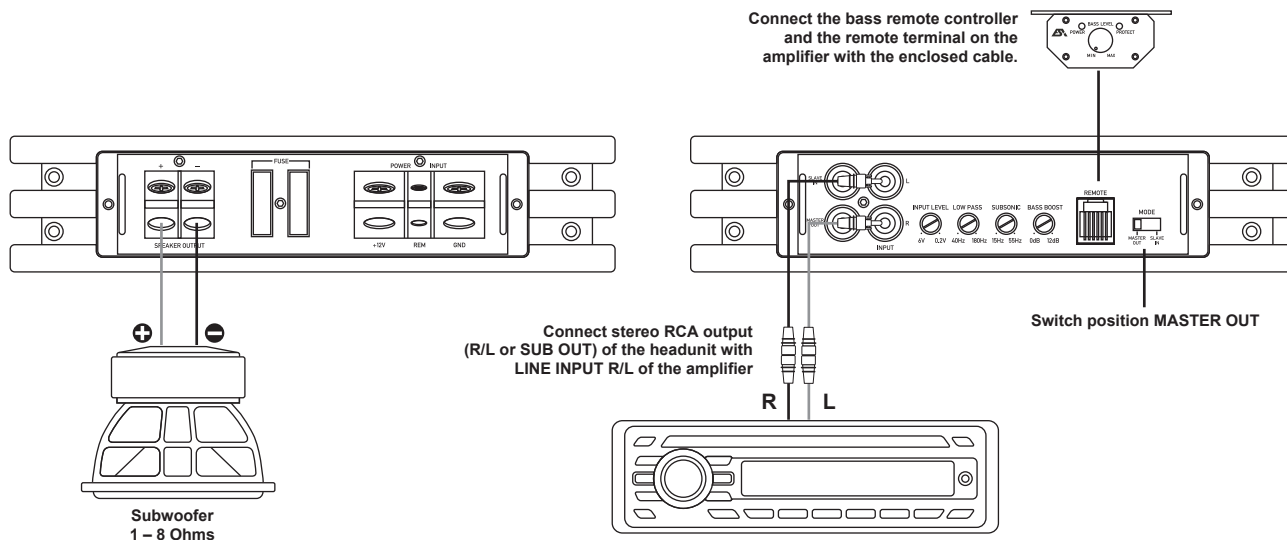

INTERCONNECTION

- Connect the RCA lineouts of the headunit with the RCA jacks LINE INPUT of the amplifier with appropriate high-value RCA cables. If your headunit is equipped with a additional subwoofer lineout (SUB OUT), it is recommended to use this lineout.
- Connect the subwoofer with the speaker outputs (SPEAKER OUTPUT + / -) by using appropriate wires.
- Ensure by any means, that the total impedance load of subwoofer is not lower than 1 ohm. Too low impedance cause high temperature and will shut down the amplifier operation.
- Always ensure the correct polarity of the speakers. The interchange of plus and minus cause total loss of bass playback and could damage the speakers.

SLAVE IN/MASTER OUT SWITCH

- The SLAVE IN/MASTER OUT switch must be in position **MASTER OUT**.

LEVEL CONTROLLER

- Turn the INPUT LEVEL controller of the amplifier to the 6V position.
- Turn the volume controller of the headunit to 80 - 90% of its full setting.
- Turn the INPUT LEVEL controller clockwise until you hear some distortion.
- Then turn back the INPUT LEVEL controller slightly until you hear a cleaner sound.

BASS BOOST CONTROLLER

- The BASS BOOST controller adjusts the bass enhancement between 0db and +12dB.
- A too high bass boost may cause clipping/distortion and damage on the loudspeakers and also may harm your hearing abilities.
Use this controller carefully!

LOW PASS CONTROLLER

- The **LOW PASS controller** adjusts the cut-off point of the frequency range to above. The cut-off frequency is continuously adjustable from 40 Hz to 180 Hz.

SUB SONIC CONTROLLER

- The **SUB SONIC controller** (Subsonicfilter) limits the ultralow and not hearable frequencies of the audiosignal to below, to avoid a mechanical and electrical overloading on the subwoofer. The cut-off frequency is adjustable from 15 to 55 Hz and depends on the size of the subwoofer.

BASS REMOTE

- The enclosed BASS REMOTE Controller adjusts the bass-level e.g. from the driver's seat. Please use only the enclosed bass remote controller and cable.

INTERCONNECTION EXAMPLE Master/Slave Mode

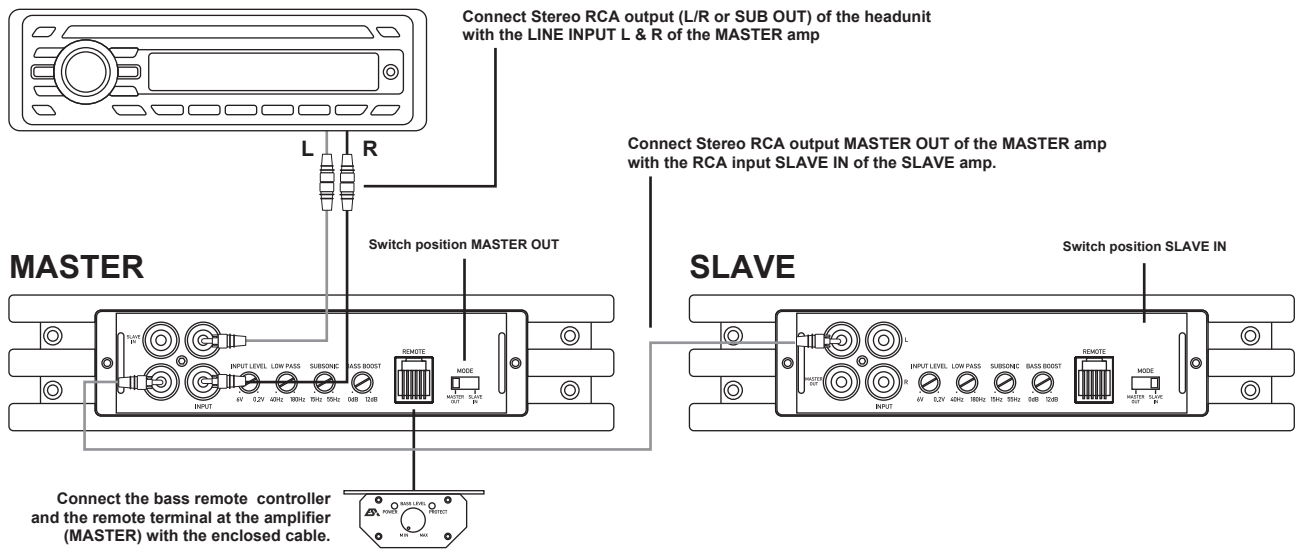

INTERCONNECTION MASTER

- Connect the RCA lineouts of the headunit with the RCA jacks LINE INPUT of the amplifier with appropriate high-value RCA cables. If your headunit is equipped with a additional subwoofer lineout (SUB OUT), it is recommended to use this lineout.
- Connect the remote wire (REM) to the remote terminal (REM) of the MASTER amp.
- Connect the bass remote wire only on the REMOTE port of the MASTER amp.

INTERCONNECTION SLAVE

- Connect the RCA jacks MASTER OUT of the MASTER amp with the RCA jacks SLAVE IN of the SLAVE amp with appropriate high-value RCA cables.
- Connect the remote wire (REM) of the remote terminal (REM) of the MASTER amp with the remote terminal (REM) of the SLAVE amp. Use therefore cable with a minimum profile section of 0,5 mm².

INTERCONNECTION SUBWOOFER

- Attend page 22.

SETTINGS MASTER

- The SLAVE IN/MASTER OUT switch should be in MASTER OUT position.
Observe the informations of LOW PASS, SUB SONIC, LEVEL, BASS BOOST, FREQ RANGE and BASS REMOTE on page 18.

SETTINGS SLAVE

- The SLAVE IN/MASTER OUT switch should be in SLAVE IN position
In SLAVE mode all controllers of the SLAVE amp are without function.
Only the already modified audiosignal of the MASTER amp will be amplified.

INTERCONNECTION EXAMPLE 1 Subwoofer with a Single-Voicecoil

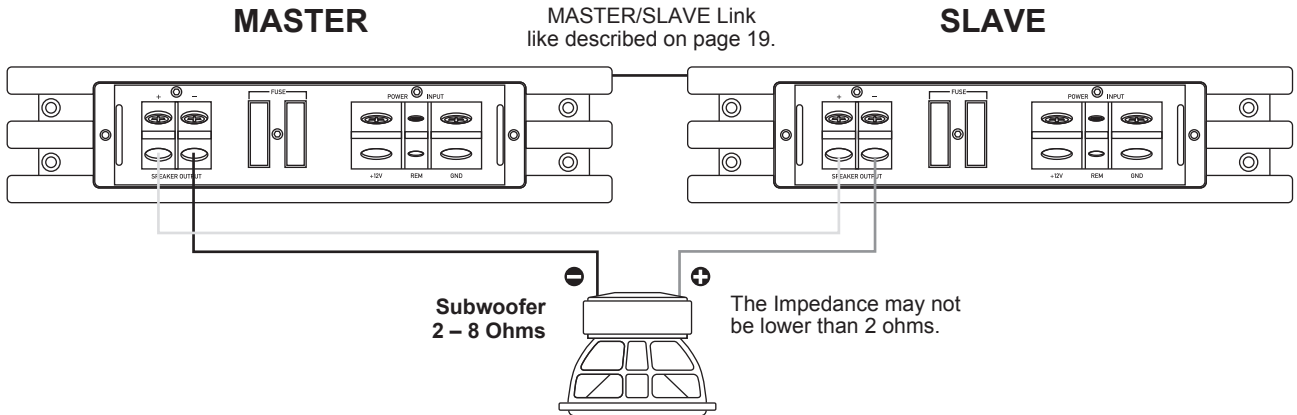

INTERCONNECTION EXAMPLE 1 Subwoofer with a Dual-Voicecoil

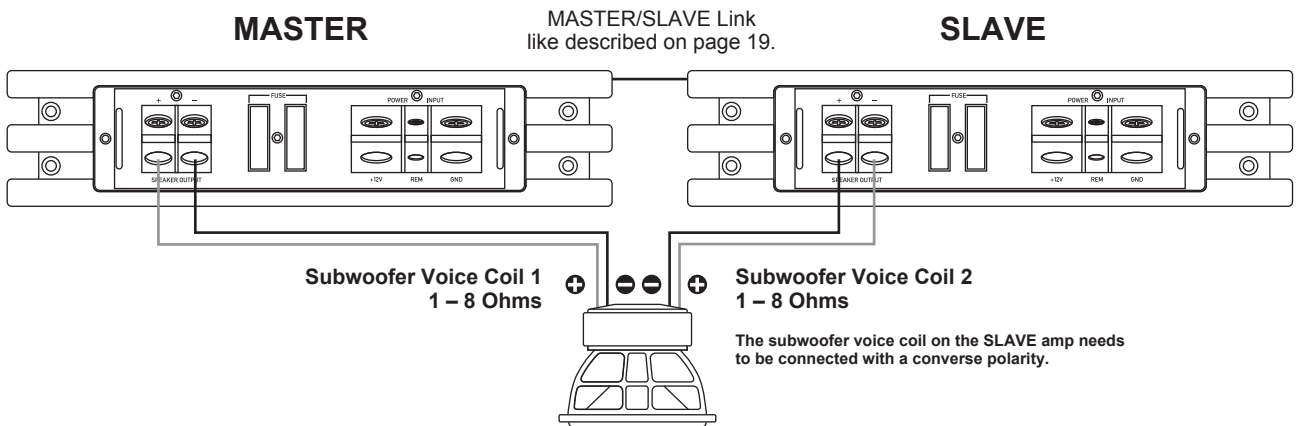

INTERCONNECTION EXAMPLE 2 Subwoofers with Single-Voicecoils

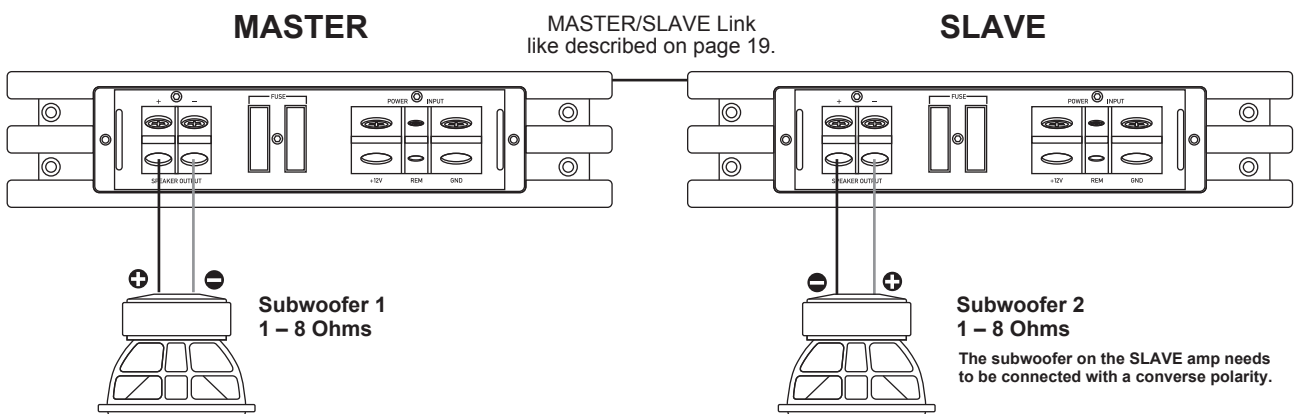

INTERCONNECTION SUBWOOFER

- Connect the Subwoofer terminals with the speaker outputs (SPEAKER OUTPUT + / -) of both amplifiers by using appropriate wires.
- Always ensure the correct polarity of the speakers. The interchange of plus and minus cause total loss of bass playback and could damage the speakers.
- Ensure by any means, that the total impedance load of subwoofer is not lower than described above.
- Too low impedance cause high temperature and will shut down the amplifier operation.

SPECIFICATIONS

MODELS	X-ONE
CHANNELS	1
CIRCUIT	CLASS D Digital
OUTPUT POWER RMS 13,8 V	
Watts @ 4 Ohms	1 x 300
Watts @ 2 Ohms	1 x 500
Watts @ 1 Ohm	1 x 750
OUTPUT POWER MAX. 13,8 V	
Watts @ 4 Ohms	1 x 600
Watts @ 2 Ohms	1 x 1000
Watts @ 1 Ohm	1 x 1500
Damping Factor	>200
Signal-to-Noise Ratio	>95 dB
THD&N	<0,1%
Input Sensitivity	6 - 0.2 V
Input Impedance	47 kOhm
FILTER	
Operation Mode	Slave - Master
Lowpassfilter	40 - 180 Hz
Bass Boost @ 45 Hz	0 - 12 dB
Subsonicfilter	15 - 55 Hz
Master/Slave Mode	Yes
Bass Remote	Yes
Slave Output (RCA)	Antiphase
Fuse Ratings	2 x 40 A
Dimensions	
Width & Height	200 x 51 mm
Length (Length total)	260 (270) mm

Technical specifications are subject to change! Errors are reserved!

For damages on the vehicle and the device, caused by handling errors of the device, we can't assume liability.

All ESX Amplifiers are tagged with a individual serialnumber, which will be registerd for statistic and service conditional purposes.

All ESX Amplifiers are tagged with a E-Certification Number and also a CE-Certification Mark. Thereby these devices are certified for the use inside vehicles inside the European Union (EU).

WARRANTY DISCLAIMER

The limited warranty comply with legal regulations. Failures or damages caused by overload, improper use or by using the product for competitions are not covered by the warranty.

Please return the defective product only with a valid proof of purchase and a detailed malfunction description.

STATUS INDICATOR & PROTECTION CIRCUIT

The STATUS INDICATOR (ESX LOGO) is located on the top side of the amplifier.

1. If the STATUS INDICATOR lights up, the amplifier is turned on and is ready for operation. You find also a POWER LED on the remote controller which owns the same function.
2. If the STATUS INDICATOR starts flashing, a malfunction occurs on the amplifier. You find also the a PROTECT LED on the remote controller which owns the same function.

Please observe in this case the following information in the section TROUBLE SHOOTING.



REFERENCE NOTE

PROTECTION CIRCUIT

This amplifier owns a 3-way protection circuit. If overloading, overheating and shorted loudspeakers, or too low impedance or insufficient power supply is insisted, the amplifier shuts down to prevent serious damage. If one of this disfunctions is detected, the STATUS INDICATOR starts flashing.

Check in this case all connections to detect short-circuits, faulty connections or overheating. Attend the regarding notes on the previous page.

If the reason for the disfunction is eliminated, the amplifier is ready for operation again.

If the STATUS LED does not stop flashing, a damage on the amplifier is insisted. In this case return the amplifier to your car audio retailer with a detailed malfunction description and a copy of the proof of purchase.

WARNING: Never open the amplifier and try to repair it by yourself. This causes a loss of warranty. The repairing service should be made only by skilled technicians.



REFERENCE NOTE

ELECTRICAL INTERFERENCES

The reason for interferences are mostly the passed cables and wires. Especially the power and audio cables (RCA) of your sound system are vulnerable. Often these interferences are caused by electric generators or other electrical units (fuel pump, AC etc.) of the car. The most of these problems can be prevented by a correct and careful wiring.

Here are some courtesy notes:

1. Use only double or triple shielded audio RCA cables for the connection between the amplifier and headunit. A useful alternative are represented by anti-noise-devices or additional ancillary equipment like Balanced Line Transmitters, which you can purchase at your car audio retailer. If possible do not use anti-noise-filters, which are splicing the ground of the RCA audio cables.
2. Do not lead the audio cables between the headunit and the amplifier together with the power supply wires on the same side of the vehicle. The best is a areal separated installation in the left and right cable channel of the vehicle. Therewith a overlap of interferences on the audio signal will be avoided. This stands also for the equipped bass-remote wire, which should be installed not together with the power supply wires, but rather with the audio signal cables.
3. Avoid ground loops by connecting all ground connections in a starlike arrangement. The suitable ground center point is ascertainable by measuring of the voltage directly on the vehicle's battery by a multi-meter. You should measure the voltage with turned-on ignition (acc.) and with other turned-on power consumers (e.g. headlights, rear window defroster, etc). Compare the measured value with the voltage of the ground point you have chosen for the installation and the positive pole (+12V) of the amplifier. If the voltage has just a little difference, you have found a suitable ground point. Otherwise you need to choose another ground point.
4. Use if possible only cables with added or soldered cable sockets or the like. Gold plated or high value nickel plated cable sockets are corrosionfree and own a very low contact resistance.

TROUBLE SHOOTING

Malfunction: no function

Reason:

1. The power supply connection of the device is not correct.
2. The cables have no mechanical or electrical contact.
3. The remote turn-on connection from the headunit to the amplifier is not correct.
4. Defective Fuses. In case of replacing the fuses, attend by any means the correct fuse rating.

Remedy:

- Recheck
- Recheck
- Recheck
- Replace Fuses

Malfunction: no signal on loudspeakers, but STATUS INDICATOR is on

Reason:

1. The connection of the speakers or the RCA audio cables is not correct.
2. The speaker cables or the RCA audio cables are defective.
3. The loudspeakers are defective.
4. Subsonic Controller is adjusted too high or Low Pass Controller is adjusted too low.
5. No signal from headunit.
6. The mode-switch is in position SLAVE.

Remedy:

- Recheck
- Replace cables
- Replace speakers
- Turn controller down or up
- Check headunit settings
- The mode-switch is in position SLAVE

Malfunction: one or more channels are without function

Reason:

1. The balance or fader controller of the headunit is not in the zero-position.
2. The connection of the speakers is not correct.
3. The loudspeakers are defective.

Remedy:

- Turn to zero-position
- Recheck
- Replace speakers

Malfunction: distortions on the loudspeaker's signal

Reason:

1. The loudspeakers are overloaded.

Remedy:

- Turn down the level
- Turn down the level on the headunit
- Switch off loudness on the headunit
- Reset bass EQ on headunit or amp

Malfunction: No bass

Reason:

1. Interchange of loudspeaker cable polarity positive (+) and negative (-).
2. The RCA audio cables are loose or defective.

Remedy:

- Reconnect
- Reconnect or replacing the cables

Malfunction: amplifier runs into protection mode (STATUS INDICATOR flashes)

Reason:

1. Short circuit on the loudspeakers or cables.
2. Overheated by too low speaker impedance.
3. Insufficient air circulation by an inappropriate mounting position of the amplifier.
4. Overloaded by insufficient power supply (too thin profile section on the power cables).

Remedy:

- Reconnect
- Choose a higher impedance
- Use a new speaker setup
- Change the mounting position
- Ensure air circulation
- Use a bigger profile section

Malfunction: hiss or white noise on the loudspeaker's signal

Reason:

1. The level controllers are turned up.
2. The speaker cables or the RCA audio cables are defective.
3. The hissing is caused by the headunit.

Remedy:

- Turn down the level
- Replacing the cables
- Check the headunit

Malfunction: no function on controller or bass remote

Reason:

1. The mode-switch is in position SLAVE.

Remedy:

- The mode-switch is in position SLAVE.



CAR AUDIO SYSTEMS



Audio Design GmbH · www.audiodesign.de
Am Breilingsweg 3 · D-76709 Kronau (Germany)
Tel. +49 (0)7253 - 9465-0 · Fax +49 (0)7253 - 946510