

BENUTZERHANDBUCH
OWNER'S MANUAL

VERS1.2



CAR AUDIO SYSTEMS

SE7000D

CLASS D MONO CAR AUDIO AMPLIFIER

TABLE OF CONTENT

SAFETY INSTRUCTIONS	16
INSTALLATION INSTRUCTIONS	17
SE7000D	19
Features and operational controls	19
Interconnection example Low Pass-Mode (standard subwoofer operation)	20
Interconnection example Master/Slave-Mode	21
FILTER SETTING RANGE	23
SPECIFICATIONS	24
TROUBLE SHOOTING	25
OPTIONAL ACCESSORIES	27



This symbol adverts you a important reference note on the following pages. Follow these reference notes by any means, otherwise damage of the device or the vehicle may be caused. Furthermore serious injuries may be caused by not following these reference notes.



REFERENCE NOTE!

VERY IMPORTANT ADVICE FOR THE INSTALLATION AND OPERATION IN NEWER VEHICLES!

In vehicles with a newer year of manufacturing (since approx. 2002), normally computer controlled diagnosis and controlling systems are applied - like CAN-BUS or MOST-BUS interfaces. By the installation of a car audio amplifier a new appliance will be added to the 12V on-board electrical system, which may cause under several circumstances error messages or may interrupt this factory made diagnosis system, as a result of high stress peaks and a higher power consumption. Thus to this, depending on model and manufacturer, the driving safety or important security systems like airbags, ESC or others could be interrupted.

If you plan to operate the amplifier in a vehicle like described above, please follow these instructions:

- **Admit the installation only by a skilled specialist, best by a service company, which is specialized on maintenance and repairing your vehicle and which is familiar with the electrical on-board system of the vehicle.**
- **After the installation, order by any means a computer based diagnosis of the on-board system by your service company to detect possible malfunctions or error messages.**
- **If the on-board system is interrupted by the installation of the amplifier, in-between installed power capacitors can stabilize the electrical on-board system and ensure a proper and stable operation.**
- **The best solution is the integration of an additional second 12 V electrical system for the complete sound system, which can be operated independently via a own battery supply.**

CONSULT BY ANY MEANS YOUR CAR SPECIALIZED SERVICE COMPANY!

PLEASE KEEP THIS MANUAL FOR LATER PURPOSES!

SAFETY INSTRUCTIONS

PLEASE ATTEND THE FOLLOWING ADVICES BEFORE THE FIRST OPERATION!

THE PURCHASED DEVICE IS ONLY SUITABLE FOR AN OPERATION WITH A 12V ON-BOARD ELECTRICAL SYSTEM OF A VEHICLE. Otherwise fire hazard, risk of injury and electric shock consists.

PLEASE DO NOT MAKE ANY OPERATION OF THE SOUND-SYSTEM, WHICH DISTRACT YOU FROM A SAFE DRIVING. Do not make any procedures, which demand a longer attention. Perform these operations not until you have stopped the vehicle on a safe place. Otherwise the risk of accident consists.

ADJUST THE SOUND VOLUME TO AN APPROPRIATE LEVEL, THAT YOU ARE STILL ABLE TO HEAR EXTERIOR NOISES WHILE DRIVING. High performance sound systems in vehicles may generate the acoustic pressure of a live concert. The permanent listening to extreme loud music may cause the loss of your hearing abilities. The hearing of extreme loud music while driving may derogate your cognition of warning signals in the traffic. In the interests of the common safeness, we suggest to drive with a lower sound volume. Otherwise the risk of accident consists.

DO NOT COVER COOLING VENTS AND HEATSINKS. Otherwise this may cause heat accumulation in the device and fire hazard consists.

DO NOT OPEN THE DEVICE. Otherwise fire hazard, risk of injury and electric shock consists. Also this may cause a loss of the warranty.

REPLACE FUSES ONLY WITH FUSE WITH THE SAME RATING. Otherwise fire hazard and risk of electric shock consists.

DO NOT USE THE DEVICE ANY LONGER, IF A MALFUNCTION, WHICH REMAINS UNREMEDIED. Check in this case the chapter TROUBLE SHOOTING. Otherwise risk of injury and the damage of the device consists. Commit the device to an authorized retailer.

THE INSTALLATION OF A POWER CAPACITOR WITH SUFFICIENT CAPACITY IS RECOMMENDED. High performance amplifiers cause high potential voltage drops and need a high power consumption at a high volume level. To relieve the vehicle's on-board system, it is recommended to install a power capacitor between the battery and the device which works as buffer. Consult your car audio retailer for the appropriate capacity.

INTERCONNECTION AND INSTALLATION SHOULD BE ACCOMPLISHED BY SKILLED STAFF ONLY. The interconnection and installation of this device demands technical aptitude and experience. For your own safeness, commit the interconnection and installation to your car audio retailer, where you have purchased the device.

DISCONNECT THE GROUND CONNECTION FROM THE VEHICLE'S BATTERY BEFORE INSTALLATION. Before you start with the installation of the sound system, disconnect by any means the ground supply wire from the battery, to avoid any risk of electric shock and short circuits.

CHOOSE A APPROPRIATE LOCATION FOR THE INSTALLATION OF THE DEVICE. Look for a appropriate location for the device, which ensures a sufficient air circulation. The best places are spare wheel cavities, and open spaces in the trunk area. Less suitable are storage spaces behind the side coverings or under the car seats.

DO NOT INSTALL THE DEVICE AT LOCATIONS, WHERE IT WILL BE EXPOSED TO HIGH HUMIDITY AND DUST. Install the device at a location, where it will be protected from high humidity and dust. If humidity and dust attain inside the device, malfunctions may be caused.

MOUNT THE DEVICE AND OTHER COMPONENTS OF THE SOUND SYSTEM SUFFICIENTLY. Otherwise the device and components may get loose and act as dangerous objects, which could cause serious harm and damages in the passenger room.

AVOID TO DAMAGE COMPONENTS, WIRES AND CABLES OF THE VEHICLE WHEN YOU DRILL THE MOUNTING HOLES. If you drill the mounting holes for the installation into the vehicle's chasis, ensure by any means, not to damage, block or tangent the fuel pipe, the gas tank, other wires or electrical cables.

ENSURE CORRECT CONNECTION OF ALL TERMINALS. Faulty connections may could cause fire hazard and lead to damages of the device.

DO NOT INSTALL AUDIO CABLES AND POWER SUPPLY WIRES TOGETHER. Avoid if possible to lead the audio cables between the headunit and the amplifier together with the power supply wires on the same side of the vehicle. The best is a areal separated installation in the left and right cable channel of the vehicle. Therewith a overlap of interferences on the audio signal will be avoided. This stands also for the equipped bass-remote wire, which should be installed not together with the power supply wires, but rather with the audio signal cables.

ENSURE THAT CABLES MAY NOT CAUGHT UP IN CLOSE-BY OBJECTS. Install all the wires and cables like described on the following pages, therewith these may not hinder the driver. Cables and wires which are installed close-by the steering wheel, gear lever or the brake pedal, may caught up and cause highly dangerous situations.

DO NOT SPLICE ELECTRICAL WIRES. The electrical wires should not be bared, to provide power supply to other devices. Otherwise the load capacity of the wire may get overloaded. Use therefor a appropriate distribution block. Otherwise fire hazard and risk of electric shock consists.

DO NOT USE BOLTS AND SCREW NUTS OF THE BRAKE SYSTEM AS GROUND POINT. Never use for the installation or the ground point bolts and screw-nuts of the brake system, steering system or other security-relevant components. Otherwise fire hazard consists or the driving safety will be derogated.

ENSURE NOT TO BEND OR SQUEEZE CABLES AND WIRES BY SHARP OBJECTS. Do not install cables and wires not close-by movable objects like the seat rail or may be bended or harmed by sharp and barbed edges. If you lead a wire or cable through the hole in a metal sheet, protect the insulation with a rubber grommet.

KEEP AWAY SMALL PARTS AND JACKS FROM CHILDREN. If objects like these will be swallowed, a risk of serious injuries consists. Consult promptly a medical doctor, if a child swallowed a small object.

INSTALLATION INSTRUCTION



REFERENCE NOTE

Before you start with the installation of the sound system, disconnect by any means the GROUND connection wire from the battery, to avoid any risk of electric shock and short circuits.

MECHANICAL INSTALLATION

Avoid any damage removing of the components of the vehicle like wires, cables, board computer, seat belts, gastank or the like.

Ensure that chosen location provide sufficient air circulation for the amplifier. Do not mount the device into small or sealed spaces without air circulation near by heat dispersing parts or electrical parts of the vehicle.

Do not mount the amplifier on top of a subwooferbox or any other vibrating parts, thereby parts in the inside of the amplifier may get loosen.

The wires and cables of power supply and the audio signal must be as short as possible, to avoid any losses and interferences.

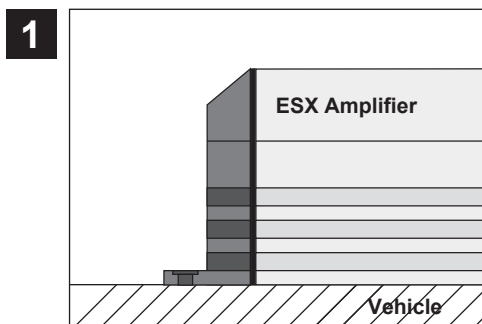

At first you need to find a suitable location to install the amplifier into the vehicle.

Check that there remains enough space for the installation of the cables and ensure that they will not be bended and have sufficient pull relief.

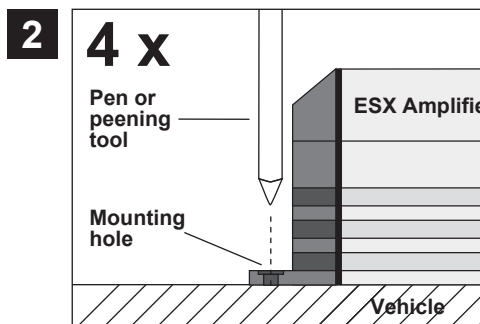

Keep the amplifier at the chosen mounting location in the vehicle.

Then mark the four drill holes with a appropriate pen or peening tool through the designated mounting holes at the amplifier.

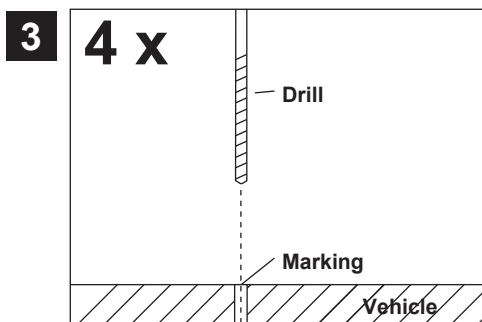

Put the amplifier aside and then drill the holes for the mounting screws at the before marked locations.

Please ensure not to damage any components of the vehicle while drilling the holes. Alternatively (depends on the material of the surface) you can also use self-tapping screws.

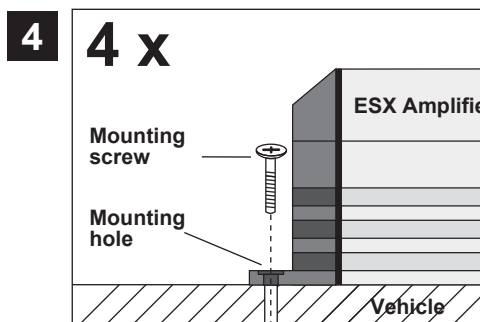

Then uphold the amplifier to the chosen position and fix the screws through the mounting holes into the drilled screwholes.

Ensure that the mounted amplifier is fixed tight and not get loosen while driving.

INSTALLATION INSTRUCTION

ELECTRICAL INTERCONNECTION

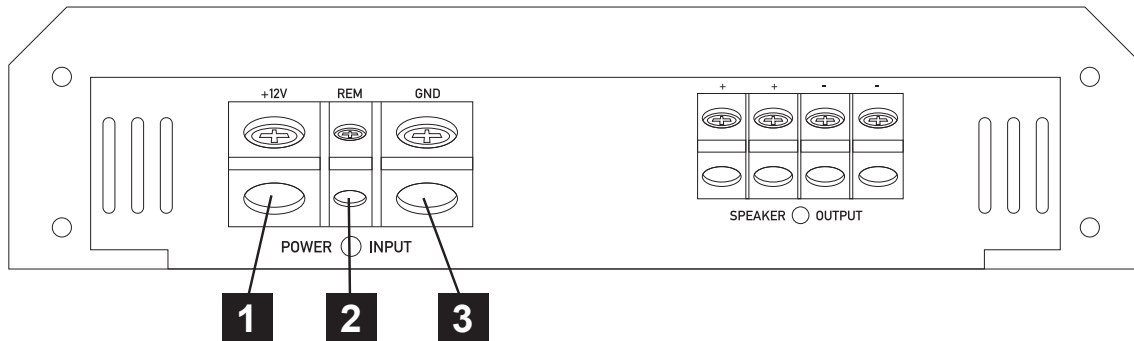

BEFORE THE CONNECTION

For the professional installation of a sound system appropriate wiring kits are available in car audio retailer stores. Attend the sufficient profile section (at least 35 mm²), the suitable fuse rating and the conductivity of the cables when you purchase your wiring kit. Clean and remove rust-streaked and oxidized areas on the contact points of the battery and the ground connection. Make sure that all screws are fixed tight after the installation, because loosely connections may cause malfunctions, insufficient power supply or interferences.

- 1 BATT+12V**
Connect the BATT+12V-terminal with the +12V pole of the vehicle's battery. Use therefor a suitable cable with a sufficient cross section (at least 35 mm²) and install a additional in-line fuse. For safety reasons the distance between the fuseblock and the battery must be shorter than 30 cm. Do not install the fuse into the fuseblock until the installation is accomplished.
- 2 REM**
Connect the turn-on signal (e.g. automatic antenna) or the turn-on remote signal of your headunit with the REM-terminal of the amplifier. Use therefor a suitable cable with a sufficient cross section (0,5 mm²). Thereby the amplifier will turn on or off automatically with your headunit.
- 3 GND**
Connect this GROUND terminal with a suitable contact ground point on the vehicle's chassis. The ground wire must be as short as possible and must be connected to a blank metallic point at the vehicle's chassis. Ensure that this ground point has a stable and safe electric connection to the negative "–" pole of the battery. Check this ground wire from the battery to the ground point if possible and enforce it, if required. Use a ground wire with a sufficient cross section (at least 35 mm²) and the same size like the plus (+12V) power supply wire.



REFERENCE NOTE

The ESX SE7000D model has due to construction-conditioned reasons **NO internal fuse-protection**. This amplifier must be fused by any means with an external In-Line-Fuse with a value of 300 A. Due to the very high power currents, only high grade quality wires and ANL fuses should be used.



REFERENCE NOTE

Installation of RCA/Audio signal cables and power supply.

Avoid if possible to lead the audio cables between the headunit and the amplifier together with the power supply wires on the same side of the vehicle. The best is a areal separated installation in the left and right cable channel of the vehicle. Therewith a overlap of interferences on the audio signal will be avoided. This stands also for the equipped bass-remote wire, which should be installed not together with the power supply wires, but rather with the audio signal cables.

FUNCTIONS AND OPERATIONAL CONTROLS

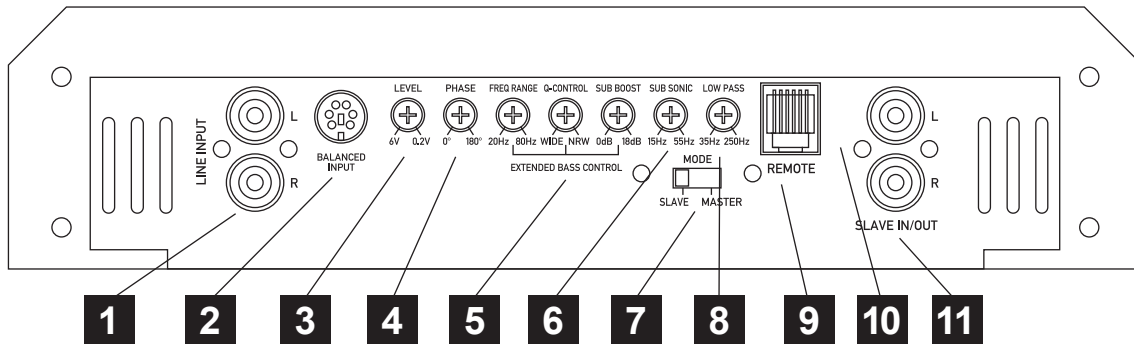

- 1** The **LINE INPUT RCA jacks** must be connected with the RCA output jacks of the headunit.
- 2** The optional **BALANCED INPUT** is unlike the regular RCA-cables insusceptible against interspersion and interferences of the vehicle's electronics. You need therefor a Balanced-Line-Transmitter with a special cable, which can be connected between the head unit and the amplifier. The Balance-Line-Transmitter is not included in delivery. **Check the information on page 27.**
⚠ Never use the Balanced-Input and the RCA-Inputs at the same time.
- 3** The **LEVEL controller** adjusts the input sensitivity of the amplifier to align the audio signal from the head unit. The input sensitivity is adjustable from 6 to 0.2 Volts.
- 4** The **PHASE controller** allows to adjust the phasing between 0° and 180°. Thereby you are able to adjust the subwoofer perfect to the vehicle's acustics.
- 5** The **EXTENDED BASS CONTROL controllers** allow a extensive adjustment of the bass frequencies.

The **SUB BOOST controller** defines the bass bosst from 0 to 18dB.

With the **FREQ RANGE controller** you are able to adjust, on which frequency the bass boost (SUB BOOST) is effective. The range goes from 20 to 80 Hz.

With the **Q CONTROL controller** defines the Q-Factor of the crossover continuously, so that the playback quality of the cut-off frequency can be adjusted. Thereby you are able to adjust perfect transitions between the loudspeakers.

 - **WIDE** equates a Q-Factor of **Q 0,3** (arrow left below) = very wide frequency range.
 - **NARROW** equates a Q-Factor of **Q 1,0** (arrow right below) = very narrow frequency range.
 - **Q 0,5 / LINKWITZ-REILLY** is the standard-setting, this means the arrow points up (12 o'clock position).
- 6** The **SUB SONIC controller** (Subsonicfilter) limits the ultralow and not hearable frequencies of the audiosignal to below, to avoid a mechanical and electical overloading on the subwoofer. The cut-off frequency is adjustable from 15 to 55 Hz and depends on the size of the subwoofer.
- 7** The **MODE switch** selects the required operation mode of the amplifier.

In the **SLAVE-Mode** the amplifier works as a SLAVE amp, this means only the audiosignal of the MASTER amp will be amplified. All controllers on the SLAVE Amp are without function and will be assumed by the MASTER amp.

In the **MASTER-Mode** (Low Pass mode) you are able to limit the frequencies to above with the LOW PASS controller. All controllers are active. **NOTE: By using only one amplifier, the Mode-Switch must set to the position MASTER.**
- 8** The **LOW PASS controller** adjusts the cut-off point of the frequency range to above. The cut-off frequency is continuously adjustable from 35 Hz to 250 Hz.
- 9** The **REMOTE port** is for the cable of the enclosed bass remote controller and only to use in the MASTER mode. With this bass remote controller, you are able to adjust the bass level e.g. out of the driver's seat. Please use only the enclosed bass remote controller and cable.
- 10** **POWER/PROTECT** (Also located on the Bass Remote unit)

If the POWER LED lights up, the amplifier is ready for operation.

If the PROTECT LED lights up, a malfunction is indicated. Attend in this case the chapter **TROUBLE SHOOTING**.
- 11** The **SLAVE IN/OUT RCA jacks** are suitable to connect an additional amplifier in MASTER/SLAVE mode. Check the chapter **Interconnection Example: MASTER/SLAVE** on page 21.

INTERCONNECTION EXAMPLE Low Pass-Mode (Standard Subwoofer Operation)

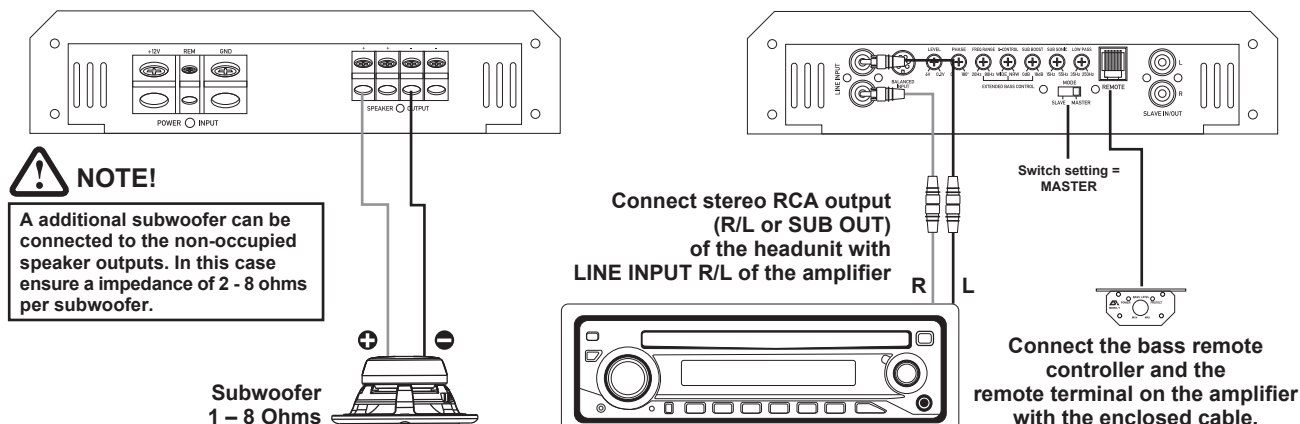

INTERCONNECTION

- Connect the RCA lineouts of the headunit with the RCA jacks LINE INPUT of the amplifier with appropriate high-value RCA cables. If your headunit is equipped with a additional subwoofer lineout (SUB OUT), it is recommended to use this lineout.
- Connect the subwoofer with the speaker outputs (SPEAKER OUTPUT + / -) by using appropriate wires.
- Ensure by any means, that the total impedance load of subwoofer is not lower than 1 ohm. Too low impedance cause high temperature and will shut down the amplifier operation.
- Always ensure the correct polarity of the speakers. The interchange of plus and minus cause total loss of bass playback and could damage the speakers.

MODE SWITCH

- The MODE switch must be in Position **MASTER**.

LEVEL CONTROLLER

- Turn the LEVEL controller of the amplifier to the 6V position.
- Turn the volume controller of the headunit to 80 - 90% of its full setting.
- Turn the LEVEL controller clockwise until you hear some distortion.
- Then turn back the LEVEL controller slightly until you hear a cleaner sound.

EXTENDED BASS CONTROL

- The SUB BOOST controller adjusts the bass enhancement between 0db and +18dB.
- A too high bass boost may cause clipping/distortion and damage on the loudspeakers and also may harm your hearing abilities.
Use this controller carefully!
- Check the further information (EXTENDED BASS CONTROL) on page 19 (Section #4).

LOW PASS CONTROLLER

- The **LOW PASS controller** adjusts the cut-off point of the frequency range to above. The cut-off frequency is continuously adjustable from 35 Hz to 250 Hz.

SUB SONIC CONTROLLER

- The **SUB SONIC controller** (Subsonicfilter) limits the ultralow and not hearable frequencies of the audiosignal to below, to avoid a mechanical and electrical overloading on the subwoofer. The cut-off frequency is adjustable from 15 to 55 Hz and depends on the size of the subwoofer.

PHASE CONTROLLER

- The **PHASE controller** allows to adjust the phasing between 0° and 180°. Thereby you are able to adjust the subwoofer perfect to the vehicle's acoustics.

BASS REMOTE

- The enclosed BASS REMOTE Controller adjusts the bass-level e.g. from the driver's seat. Please use only the enclosed bass remote controller and cable.

INTERCONNECTION EXAMPLE Master/Slave Mode

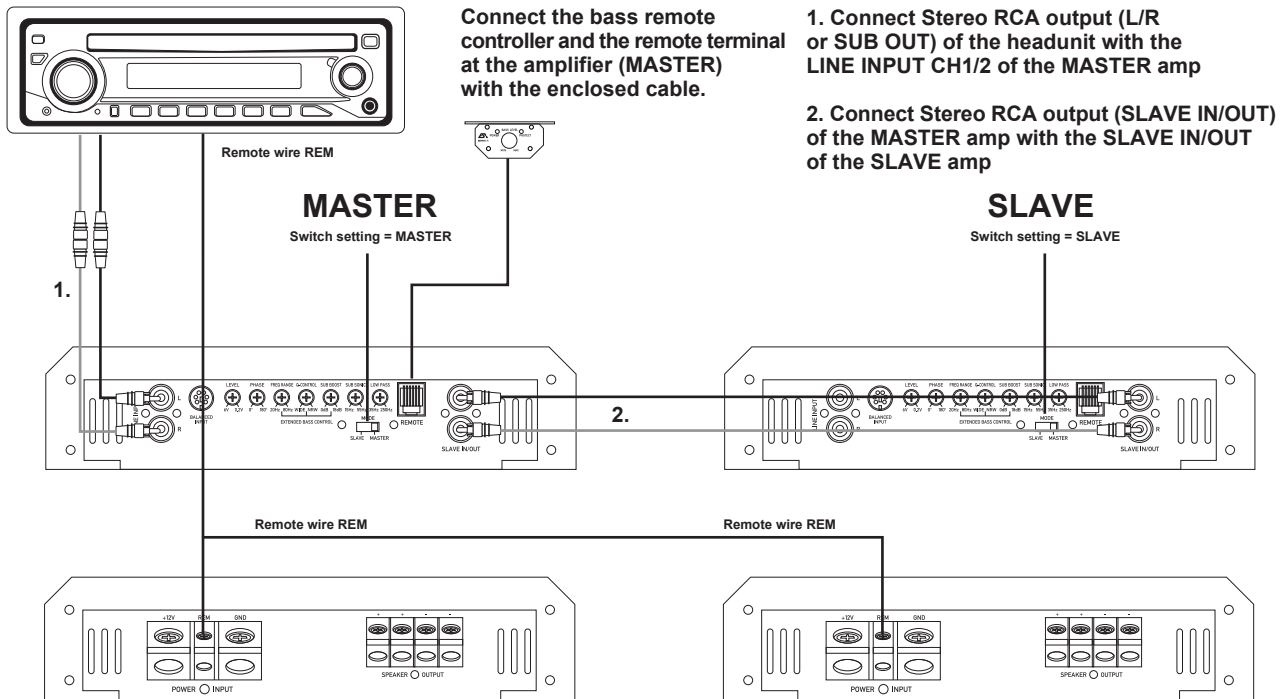

INTERCONNECTION MASTER

- Connect the RCA lineouts of the headunit with the RCA jacks LINE INPUT of the amplifier with appropriate high-value RCA cables. If your headunit is equipped with a additional subwoofer lineout (SUB OUT), it is recommended to use this lineout.
- Connect the remote wire (REM) to the remote terminal (REM) of the MASTER amp.
- Connect the bass remote wire only on the REMOTE port of the MASTER amp.

INTERCONNECTION SLAVE

- Connect the RCA jacks SLAVE IN/OUT of the MASTER amp with the RCA jacks SLAVE IN/OUT of the SLAVE amp with appropriate high-value RCA cables.
- Connect the remote wire (REM) of the remote terminal (REM) of the MASTER amp with the remote terminal (REM) of the SLAVE amp. Use therefore cable with a minimum profile section of 0,5 mm².

INTERCONNECTION SUBWOOFER

- Check page 22.

SETTINGS MASTER

- The MODE switch should be in MASTER position.

Check the information of LOW PASS, SUB SONIC, PHASE, LEVEL, SUB BOOST, FREQ RANGE, Q-CONTROL and BASS REMOTE on page 20.

SETTINGS SLAVE

- The MODE switch must be in SLAVE position.

In the SLAVE mode all controllers of the SLAVE amp are without function. Only the already modified audiosignal of the MASTER amp will be amplified.

INTERCONNECTION EXAMPLE 1 Subwoofer with a Single-Voicecoil

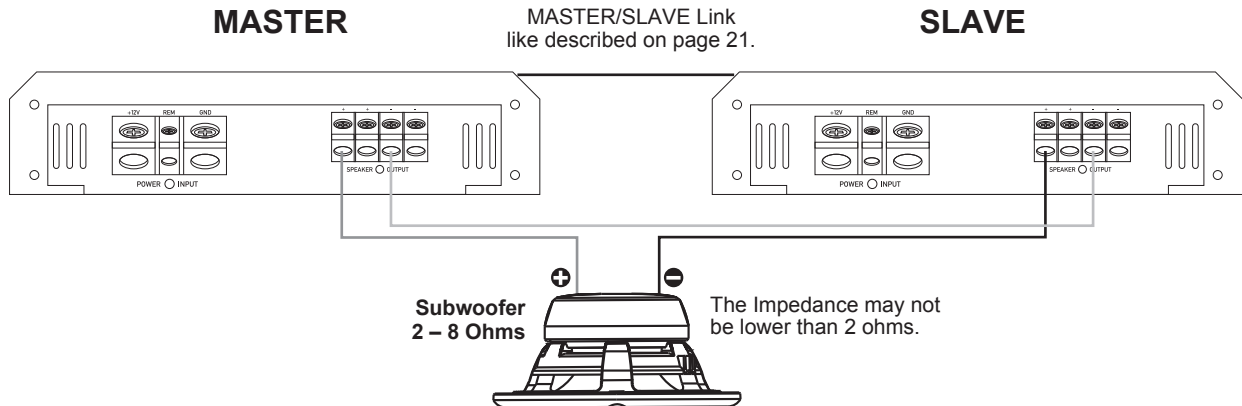

INTERCONNECTION EXAMPLE 1 Subwoofer with a Dual-Voicecoil

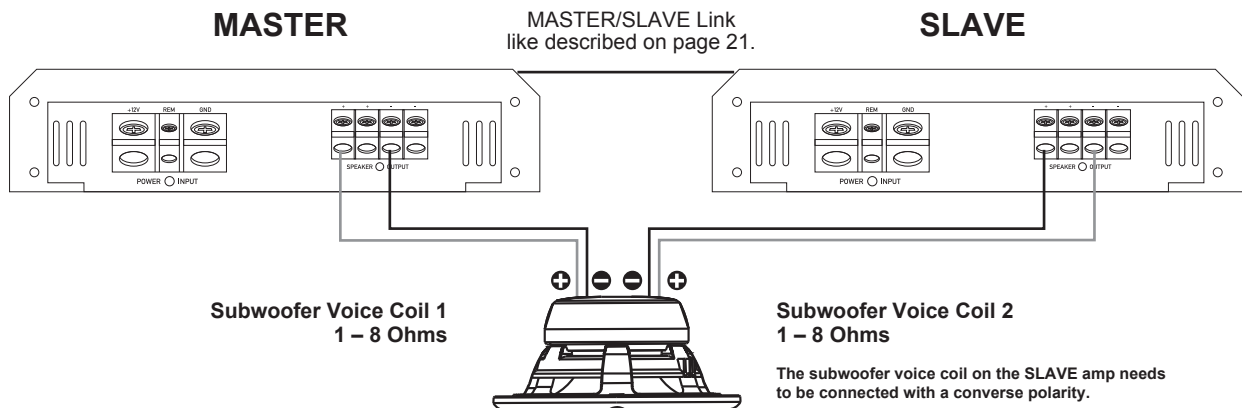

INTERCONNECTION EXAMPLE 2 Subwoofers with Single-Voicecoils

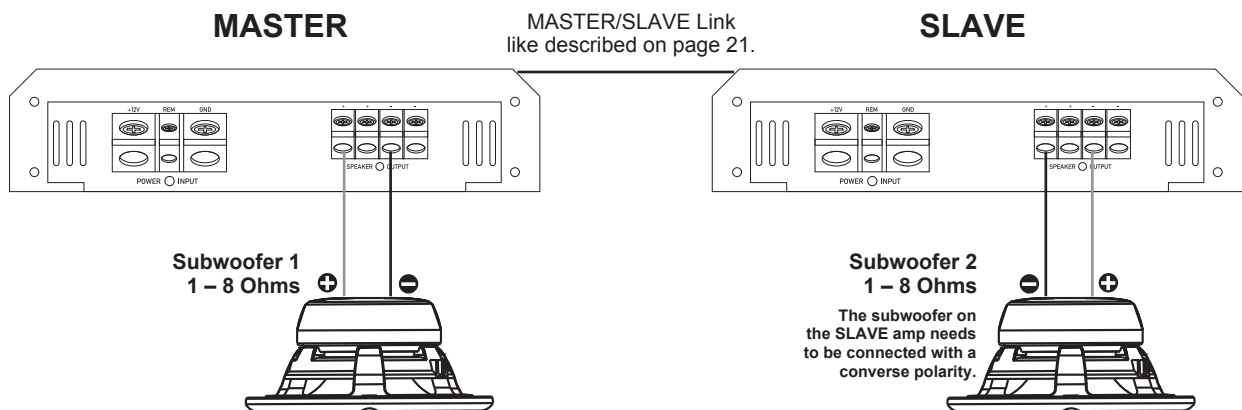

INTERCONNECTION SUBWOOFER

- Connect the Subwoofer terminals with the speaker outputs (SPEAKER OUTPUT + / -) of both amplifiers by using appropriate wires.
- Always ensure the correct polarity of the speakers. The interchange of plus and minus cause total loss of bass playback and could damage the speakers.
- Ensure by any means, that the total impedance load of subwoofer is not lower than described above.
- Too low impedance cause high temperature and will shut down the amplifier operation.

FILTER SETTING RANGE

LEVEL

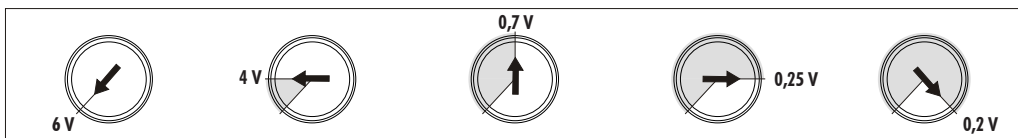

SUB SONIC

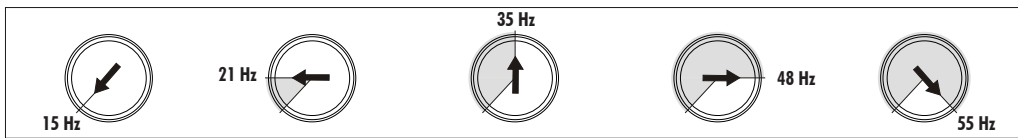

LOW PASS

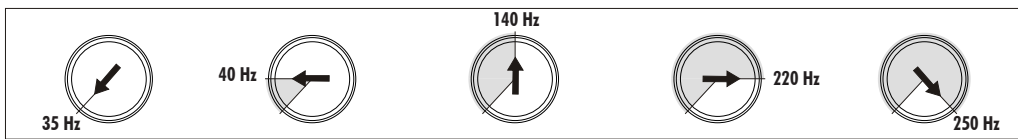

EXTENDED BASS CONTROL

SUB BOOST

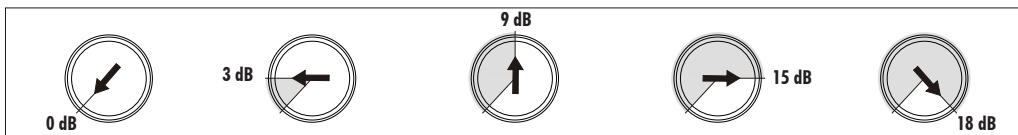

FREQ RANGE

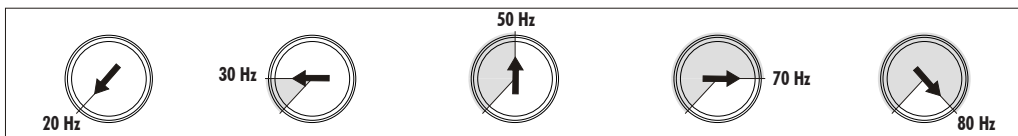

PHASE

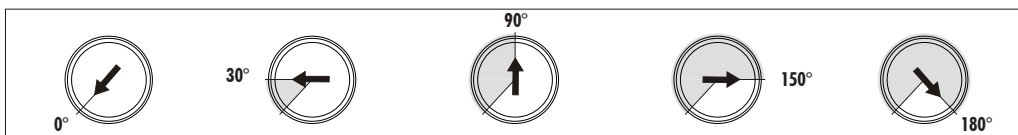

WIDE Q-CONTROL NARROW

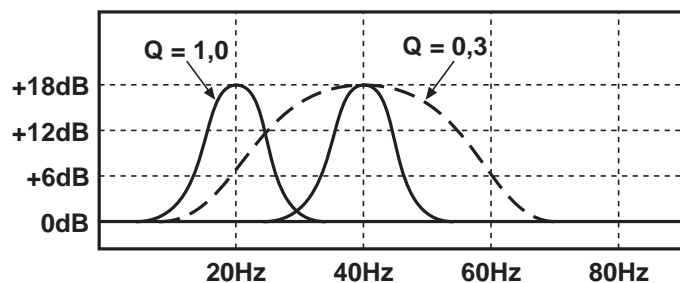
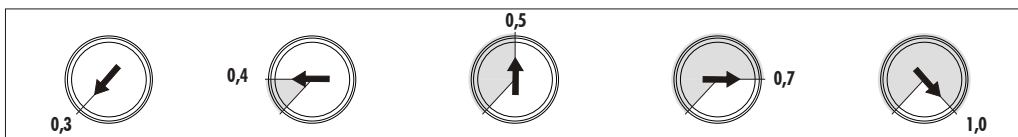

SPECIFICATIONS

MODELS	SE7000D
CHANNELS	1
CIRCUIT	CLASS D Digital
OUTPUT POWER RMS 13,8 V	
Watts on 4 Ohms	1 x 1250
Watts on 2 Ohms	1 x 2000
Watts on 1 Ohms	1 x 3500
OUTPUT POWER MAX. 13,8 V	
Watts on 4 Ohms	1 x 2500
Watts on 2 Ohms	1 x 4000
Watts on 1 Ohms	1 x 7000
Damping Factor	200
Signal-to-Noise Ratio	90 dB
THD&N	0,1%
Input Sensitivity	6 - 0.2 V
Input Impedance	47 kOhm
FILTER	
X-Over Modes	Slave - Master
Various Lowpassfilter	35 - 250 Hz
Sub Boost @ 20 - 80 Hz	0 - 18 dB
Q-Control	WIDE - NARROW
Subsonicfilter	15 - 55 Hz
Phase shift	0 - 180°
Master/Slave Mode	•
Bass Remote	•
Balanced Input	•
Slave Output (RCA)	•
Fuse Ratings	300 A (external)
Dimensions	
Width & Height	257 x 60 mm
Length (Length total)	550 (600) mm

Technical specifications are subject to change! Errors are reserved!

For damages on the vehicle and the device, caused by handling errors of the device, we can't assume liability.

All ESX Amplifiers are tagged with a individual serialnumber, which will be registerd for statistic and service conditional purposes.

All ESX Amplifiers are tagged with a E-Certification Number and also a CE-Certification Mark. Thereby these devices are certified for a use inside vehicles inside the European Union (EU).

The warranty conditions comply to the common consumer acts of the European Union (EU).

TROUBLE SHOOTING

Malfunction: no function

Reason:

1. The power supply connection of the device is not correct.
2. The cables have no mechanical or electrical contact.
3. The remote turn-on connection from the headunit to the amplifier is not correct.
4. Defective Fuses. In case of replacing the fuses, attend by any means the correct fuse rating.

Remedy:

- Recheck
- Recheck
- Recheck
- Replace Fuses

Malfunction: no signal on loudspeakers, but power LED lights up

Reason:

1. The connection of the speakers or the RCA audio cables is not correct.
2. The speaker cables or the RCA audio cables are defective.
3. The loudspeakers are defective.
4. Subsonic Controller is adjusted too high or Low Pass Controller is adjusted too low.
5. No signal from headunit.

Remedy:

- Recheck
- Replace cables
- Replace speakers
- Turn controller down or up
- Check headunit settings

Malfunction: one or more channels are without function

Reason:

1. The balance or fader controller of the headunit is not in the zero-position.
2. The connection of the speakers is not correct.
3. The loudspeakers are defective.

Remedy:

- Turn to zero-position
- Recheck
- Replace speakers

Malfunction: distortions on the loudspeaker's signal

Reason:

1. The loudspeakers are overloaded.

Remedy:

- Turn down the level
- Turn down the level on the headunit
- Switch off loudness on the headunit
- Reset bass EQ on headunit or amp

Malfunction: No bass

Reason:

1. Interchange of loudspeaker cable polarity positive (+) and negative (-).
2. The RCA audio cables are loose or defective.

Remedy:

- Reconnect
- Reconnect or replacing the cables

Malfunction: amplifier runs into protection mode (red protection LED lights up)

Reason:

1. Short circuit on the loudspeakers or cables.
2. Overheated by too low speaker impedance.
3. Insufficient air circulation by an inappropriate mounting position of the amplifier.
4. Overloaded by insufficient power supply (too thin profile section on the power cables).

Remedy:

- Reconnect
- Choose a higher impedance
- Use a new speaker setup
- Change the mounting position
- Ensure air circulation
- Use a bigger profile section

Malfunction: hiss or white noise on the loudspeaker's signal

Reason:

1. The level controllers are turned up.
2. The speaker cables or the RCA audio cables are defective.
3. The hissing is caused by the headunit.

Remedy:

- Turn down the level
- Replacing the cables
- Check the headunit

Malfunction: no function on controller or bass remote

Reason:

1. The mode-switch is in position SLAVE.

Remedy:

- Set switch to position MASTER



REFERENCE NOTE

PROTECTION CIRCUIT

This amplifier owns a protection circuit. If overloading, overheating and shorted loudspeakers, or too low impedance or insufficient power supply is insisted, the amplifier shuts down to prevent serious damage. If one of this disfunctions is detected, the red PROTECT LED lights up.

Check in this case all connections to detect short-circuits, faulty connections or overheating. Check the regarding notes on the previous page.

If the reason for the disfunction is eliminated, the amplifier is ready for operation again.

If the red PROTECT LED does not stop to light up, a damage on the amplifier is insisted. In this case return the amplifier to your car audio retailer with a detailed malfunction description and a copy of the proof of purchase.

WARNING: Never open the amplifier and try to repair it by yourself. This causes a loss of warranty. The repairing service should be made only by skilled technicians.



REFERENCE NOTE

ELECTRICAL INTERFERENCES

The reason for interferences are mostly the passed cables and wires. Especially the power and audio cables (RCA) of your sound system are vulnerable. Often these interferences are caused by electric generators or other electrical units (fuel pump, AC etc.) of the car. The most of these problems can be prevented by a correct and careful wiring.

Here are some courtesy notes:

1. Use only double or triple shielded audio RCA cables for the connection between the amplifier and headunit. A useful alternative are represented by anti-noise-devices or additional ancillary equipment like Balanced Line Transmitters, which you can purchase at your car audio retailer. If possible do not use anti-noise-filters, which are splicing the ground of the RCA audio cables.
2. Do not lead the audio cables between the headunit and the amplifier together with the power supply wires on the same side of the vehicle. The best is a areal separated installation in the left and right cable channel of the vehicle. Therewith a overlap of interferences on the audio signal will be avoided. This stands also for the equipped bass-remote wire, which should be installed not together with the power supply wires, but rather with the audio signal cables.
3. Avoid ground loops by connecting all ground connections in a starlike arrangement. The suitable ground center point is ascertainable by measuring of the voltage directly on the vehicle's battery by a multi-meter. You should measure the voltage with turned-on ignition (acc.) and with other turned-on power consumers (e.g. headlights, rear window defroster, etc). Compare the measured value with the voltage of the ground point you have chosen for the installation and the positive pole (+12V) of the amplifier. If the voltage has just a little difference, you have found a suitable ground point. Otherwise you need to choose another ground point.
4. Use if possible only cables with added or soldered cable sockets or the like. Gold plated or high value nickel plated cable sockets are corrosionfree and own a very low contact resistance.

BALANCED LINE TECHNOLOGY

BALANCED INPUT

With the optional BALANCED INPUTS, ESX offers an absolutely state-of-the-art-technology. Balanced inputs have been used for many years in professional sound studios and high end home stereo systems. Unlike the regular unbalanced RCA's connections, balanced wires are insusceptible against interferences of the vehicle's electronics. Therefor an separate signal transmitter like described below is required.

SUITABLE ESX BALANCED LINE TRANSMITTER



SX2BLT

Balanced-Line-Transmitter for 2-Channel- or Mono-Amplifiers in a stable metal-housing. With RCA-Inputs and Balanced-Line-Outputs. Incl. Balanced Line Cable (5 m).



SX4BLT

Balanced-Line-Transmitter for 4-Channel- or two Mono-Amplifiers in a stable metal-housing. With RCA-Inputs and Balanced-Line-Outputs. Incl. 2 x Balanced Line Cable (5 m).